



TCLinic

TURN INDICATOR by Barney (Doc) Jackson

How many times have you seen the car ahead of you (TC, of course!) complete a turn and go racing off with the turn signals winking and blinking? After all, who could hear that flasher clicking over the satisfying rumble of the gearbox or the authoritative crack of the exhaust or the contented valve clatter of the engine? Or, who notices that little red pilot light always hidden behind the rim of the steering wheel and completely cancelled out by bright sunlight?

At this point you get prescription #109 (no not an Excedrin headache - I've got that). Guess what it is . . . can't guess? Okay, I'll have to tell—it's a buzzer. That's right, a plain old everyday doorbell type buzzer placed in the flasher circuit, on the "P" or "L" terminals on the flasher unit and ground (see sketch below). When the signals are flashing - it makes a satisfying Bzzz, Bzzz, Bzzz. Satisfying? - it annoys the hell out of me, maybe that's why I always TURN MY TURN SIGNALS OFF!

First printed by TCMG in 1970

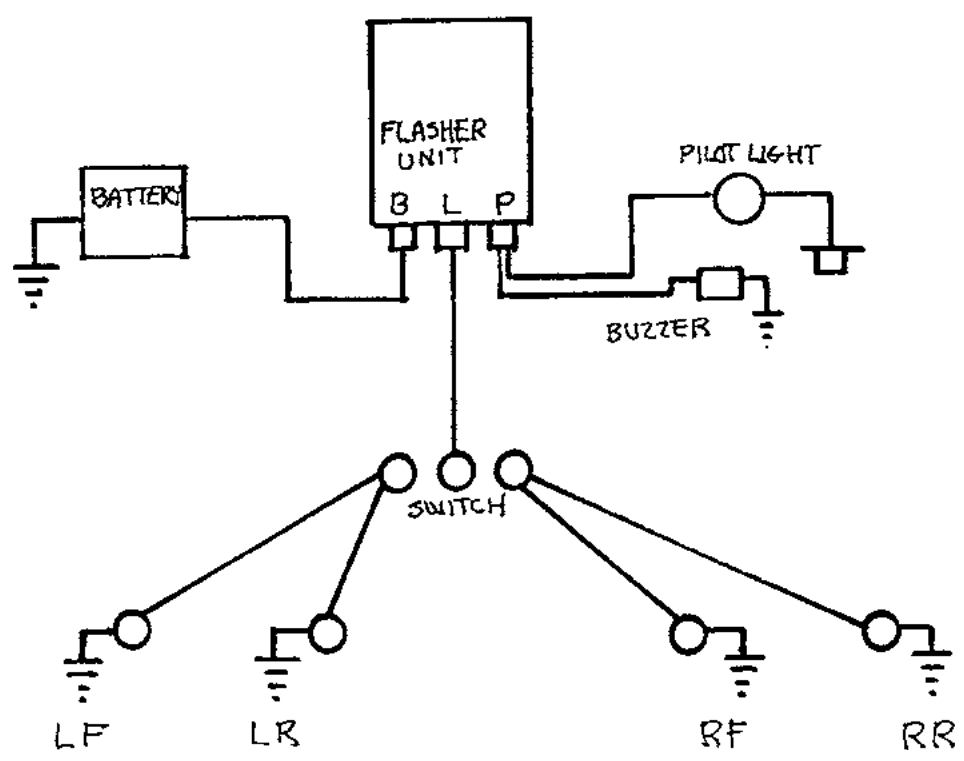

2002 Update

This article was first written as Med-i-car #2, part of a series by Barney Jackson. Med-i-car #1 and #3 are TC Clinics #2 and 46 respectively.