

THE MGTC FRONT END

Jim Buell

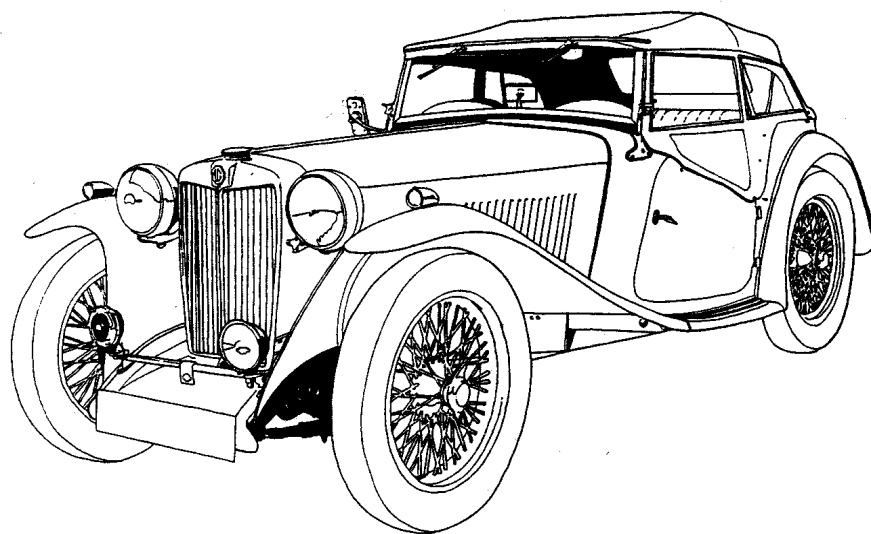

Second Edition

1991, 2002 by the author. All rights reserved.

TABLE OF CONTENTS

ACKNOWLEDGEMENT	3
INTRODUCTION	3
PRELIMINARIES	
Chassis	5
Rubber Bushings	5
Dampers	6
Rear Axle	6
Tires	6
Wheels	7
Balance	7
THE COMPONENTS	
Steering Box and Column	9
Track Rod and Drop Arm	11
Front springs	12
Front axle	13
King pins	14
Spindles	15
Hubs	16
Lubrication	17
ALIGNMENT – Some basic theory	
Camber	18
Caster	18
Toe-in	19
Steering arms	19
ALIGNMENT – How To	
The equipment	21
Preparation	21
Caster	22
Camber	22
Toe-in	22
APPENDIX A	
Tapered Roller Bearings	24

LIST OF FIGURES

Figure 1 - Effects of incorrect set-up	7
Figure 2 - Drop arm assembly	11
Figure 3 - Track rod assembly	12
Figure 4 - Transmission of forces	12
Figure 5 - Front spring, rear shackle	13
Figure 6 - Camber angle	18
Figure 7 - Caster angle	18
Figure 8 - Taper packing	19
Figure 9 - Single pivot turning radius	20
Figure 10 – Ackerman steering	20
Figure 11 – Simple measuring device	21
Figure 12 – Sighting front wheels	21
Figure 13 – Sight lines for measure.	22
Figure 14 – Toe-in measuring device	23

ACKNOWLEDGMENT

A special Thank You goes to Al Moss for sharing his extensive knowledge of the MGTC front end. This booklet was derived from talks given by Al at GoF West '86 in San Diego and GoF West '98 in Monterey

I would also like to thank all those who have reviewed the manuscript and the helpful comments and contributions they have provided.

A special acknowledgement is in order to all those who have written articles in their club newsletters and have shared their knowledge with others - many of those pieces have been extensively used as source material (see especially the work of F.E. Old III and Doug McGowan in the April 1978 TSO). Because of the way we share information via our various newsletters specific authorship is frequently unknown. I do, however, give credit to all of you. Thank you!

Finally, I appreciate all the comments, suggestions and discussions the first edition elicited.

The author encourages users of this booklet to make corrections, additions or comments. They should be addressed to:

Jim Buell
6915 Lakeview Dr.
Salinas, CA 93907
(831) 663-4606
gmparcr@redshift.com

INTRODUCTION

The purpose of this booklet is to let you know how the front end of an MGTC works. It will cover some of the principles used in the design, what components are involved and how to repair or refurbish them.

There are several dozen books (at least!) and thousands of articles that contain information about the maintenance of our cars. There are several that deserve mention and should be in the library of every TC owner:

_____. *The Instruction Manual for the MG Series "TC" Midget.* Abingdon-on-Thames: The M.G. Car Company, Ltd.

Blower, W.F. 1952. *The M.G. Workshop Manual.* London: Motor Racing Publications.

Sherrel, Michael. 1990. *TC's FOREVER.* Singapore: Stamford Press.

"The Sacred Octagon".
Publication of the New England MGT Register. Various technical articles (index available)

The TC is known for its wide range of steering agility as well as for its many perceived steering faults. Over the years abuse, poor maintenance, modifications, and meeting hard objects have taken their toll. Today there are very few, if any, shops or mechanics who even recognize a TC, much less have the knowledge or equipment to work on them. The main body of knowledge and experience rests with the mechanically inclined enthusiast. TC owners must learn about their cars and be able to maintain them themselves or be

able to supervise a local shop. While care has been taken to ensure correctness of information it is obviously not possible to guarantee complete freedom from errors or to accept liability arising from such errors or omissions.

balance the suggestions given against your need for originality.

A Caution! It is important to note that repair procedures, techniques, tools, parts, and the skill and experience of the individual performing the work vary widely. It is not possible to anticipate all of the conceivable ways or conditions under which our cars may be used or to provide cautions as to all of the possible hazards that may result. Standard and accepted safety precautions and equipment should be used when handling toxic or flammable fluids, and safety goggles or other protection should be used during cutting, grinding, chiseling, prying, or any other process that can cause material removal or projectiles. Some of the procedures described may require the use of tools specially designed for a specific purpose. Before substituting another tool or procedure, you must be completely satisfied that neither your personal safety, nor the performance of your TC will be endangered.

The TC is not a modern car and does not have modern suspension or components, therefore it will never handle like a car off the 90's showroom floor. However, driving a TC can and should be a pleasurable experience. With some work on your part you can get your TC, no matter what shape it is in to steer and handle properly.

Material in this booklet that is in *italics* are departures from the way our cars were built at the factory. You must

PRELIMINARIES

The TC steering is a wholistic function of the frame and suspension as well as the steering mechanism. If all the parts are not in harmony the agility suffers. There are no shortcuts - you must check the entire system.

Chassis

The first step in the process is to determine if the chassis itself is straight and true in all directions. If you have chassis problems, no matter how good the front end and steering are, it's still not going to handle properly.

It is quite easy for a frame of this type to get "diamonded"; in other words out of square - sides parallel but cross braces not perpendicular. It doesn't take much of a hit on the corner of the frame to get it out of square. The TC owners manual has a diagram of the chassis with dimensions. To check the frame yourself:

- Park the car on a clean, level floor. (If your floor is not clean, put wide butcher down under the car).
- Find each of the reference points shown on the diagram and mark them on the frame. Using a plumb bob, transfer the reference points to the floor or paper. You can do this a lot easier if the car is stripped down; if not, you will have to do it with the car assembled (it is a bit awkward working under the car, but it can be done).
- Now measure. If the measurements are beyond the limits shown on the frame drawings, the frame must be straightened. (This is a job best left to the professionals.)

- Check the frame carefully and thoroughly for cracks, damaged areas, loose bolts and rivets, rust and loose or damaged mounting brackets. There are several areas that need special attention:
 - First is the attachment point for the front engine mounts. There are four bolt on either side. Cracks can develop there because of the constant engine vibration. These cracks can easily be repaired by welding.
 - Second, Check the front dumbirons—these are the little gadgets that slip into the frame and the front cross-tube goes through. There is a long rivet that goes through there, and that rivet can fail. If you use a hardened bolt to replace the rivet, grind the head down so it fits under the splash pan.

Rubber Bushings

Check all the rubber bushings. They are used on the rear of the front springs and both ends of the rear springs and on the damper links.

- Make sure they are good and tight. Replace the bushings if they are hard, cracked or worn. Rubber bushes are readily available. *For a more firm and stable ride install polyurethane bushings.*
- Check the shock link studs on the spring mounting plates. They should be tight and clean. Replace them if they show signs of rust or wear.

A note about shock link bushings. The bushings supplied today do not fit quite as snugly as the originals. To prevent the link from coming loose or popping out of the bushing, drill a 9/64" diameter hole through the link about 3/16" from the end. Put a 1/2"

flat washer on the end and retain it with a 1/8" split pin through the hole.

Dampers (Shock absorbers)

Top off the dampers then take the lower link loose from the spring.

- Cycle each damper to its full extension several times. They should move smoothly, resist the movement, and all should be about equally resistant.
- There should be no evident leaks.

If leaks are evident or the movement between the dampers is inconsistent, they probably should be rebuilt.

The dampers on the TC, if maintained properly, do much to improve the ride. In addition they limit the travel of the springs and prevent spring failure. The only adjustment (stiffening) possible is to vary the weight of the oil used in them. *Most commonly, this oil is available from motorcycle shops (it's called fork oil) and comes in various weights (viscosity) generally starting with 0 as the lightest, and progressing to 30 as the heaviest. The particular weight oil you use will be a matter of personal preference depending on the ride you want (20 is a good starting place).*

Rear Axle

Next, check the rear axle closely.

- Pay particular attention to the rear axle housing and bracket (spring perch). They have been known to crack badly. Repair and/or add reinforcing straps if necessary
- On each side there are four bolts through to the spring. They should be set up quite tight (not like a TD where you have rubber in it) and they should be double nutted so

they can't come loose. Check them periodically to make sure they stay tight. You may want to consider replacing these rather soft bolts with 5/16 hardened spring center or other hardened bolts.

- Be sure the rear axles are tight in the hubs. Make sure the big bearing retaining nut is tight on the axle tube. This nut locks the bearing onto the axle casing. Also the outer spigot on the hub contacts the outer bearing race in the bearing carrier. A gap of 0.004" between the flanges will ensure the outer race has a slight pre-load. Failure to securely tighten the bearing nut and locate the outer race in the bearing carrier will cause oil leaks, stress on the axle housing and stress on the axle potentially causing premature failure. If hubs are loose, they may need to be replaced. If you can grab the wheel and wobble it, you've got problems and your car is not going to handle well until you get it solved.

Tires

The TC does not normally show a lot of abnormal tire wear; probably, because we don't drive them that much. You can determine a lot about the state of your alignment by looking at the tires.

- On a tire with a block pattern tread, the tread blocks on the rear tires wear evenly because every time you start out it tends to pull the rubber back and every time you stop it tends to push it forward, and the resulting wear balances out. But the front tires take pressure only when stopping, so if you don't rotate the tires you're going to get a constant cupping back on each tread block. Any time you look at a tire and it shows this slight backward cupping, that is wear from braking. There's nothing wrong with it except the tires

haven't been rotated often enough. (This pattern does not occur on radial groove treads.)

- If you get a section somewhere on the tire where there's a great big cup (or it may do it in several places all the way around the tire), this is probably from high-low spots in your brake drum or an out of balance condition. The high-low spots in the drum will cause the tire to want to stop in the same place each time. It could also be dampers that are not functioning properly and allowing the tire to bounce.
- If your tires are showing wear on the insides or outsides it is generally a camber condition - too much camber and the outside of the tire wears. Negative camber would wear on the inside. (See Figure 1A)
- Toe-in can also affect tire wear. Excessive toe-in or tow- out causes the tread to scuff and produces "feathering" or slanted wear on each tread ridge. (See Figure 1B)

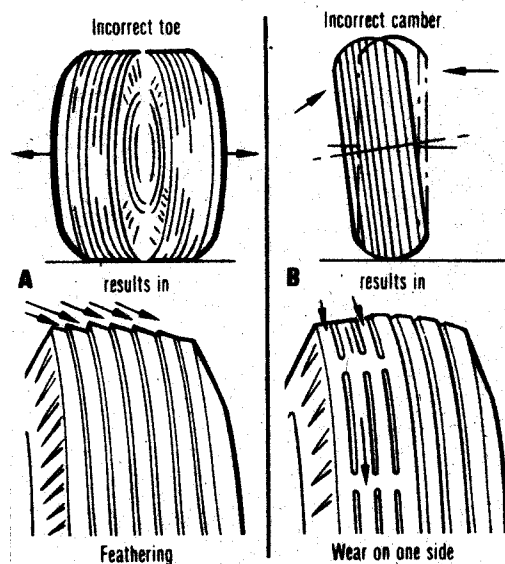

Figure 1 – Effects of incorrect set-up

Tire pressure is critical on these cars - 30 to 32 pounds when cold is best. Everything else being equal, the lower the tire pressure you start out with in a car, the higher it's going to go when it gets hot. Most people feel that you have to run with lower pressure so it rides softer. It may start out that way but it doesn't stay that way long. Instead of 32 pounds, say you start out with 18 or 20 pounds. The tire is going to flex a lot at the point where it makes contact with the road. The more it flexes the hotter it gets, and the hotter it gets the air pressure goes up. That is why the pressure should always be checked with the tires cold.

Wheels

The wire wheels on a TC are called "center laced" meaning that the spokes go from the hub to the raised center of the rim. There are 48 spokes.

- Make sure that all the spokes are tight and that none are broken. Tap each spoke lightly and see if you get a ringing sound. A "thud" means the spoke is loose or broken.
- Be sure all five of the road wheels (that includes the spare) are running true. One way to check this is to use an oil can with a curved metal spout. It is just about the right height. Jack up the front of the car so that the front tires just clear the ground. Put the spout against the edge of the rim and spin the wheel. You will be able to see run in and out and if there is any wobble up and down. They should run concentrically and shouldn't wobble. They should be true to within 1/16" max. If they are not running true have them straightened.

Balance

Another problem that could be encountered is shimmy, although it is not

very common on the TCs. This is usually caused by an out of balance condition. Alignment problems such as too much caster can cause it but it is most commonly an out of balance condition. It is possible to balance your TC wheels fairly simply. There are two types of balance: static and dynamic. You really can't do much dynamic balancing without a wheel balancer, and most tire shops are not equipped to handle wire wheels.

The procedure for static balance is as follows:

- Put the wheels on the front, especially before you tighten down the wheel bearings so that the wheel spins easily.
- Back off the brakes so there is no drag.
- Spin the wheel slowly and it will stop with the heavy part at the bottom.
- Wrap solder around the spokes at the top. Keep doing this until there is no noticeable heavy point.

Instead of using solder another alternative is to go to a tire shop and buy stick-on weights. These are the kind most commonly used on mag style wheels. They come in strips and can be cut in different lengths to achieve the proper weight. The only way these weights work permanently, once you have the proper weight distribution, is to remove the sticky backing (with lacquer thinner) and mix up some two-part epoxy and that will really glue them on. If you use this kind of weight, for best results split the weight on the inside and the outside of the wheel.

THE COMPONENTS

This section will go through the front end and steering step-by-step. It assumes you've just bought a doggy old TC and it is all over the road and you really want to do it right. You can certainly bypass one of the steps covered here if you know that your car doesn't need that work done. This also assumes that you have done the inspection of the chassis described above and made any corrections or restorations found necessary.

Steering Box and Column

The first thing to do is remove the steering box and column from the car.

- Take the steering wheel off, remove the clamp under the fascia, take the three bolts out of the frame and remove the drop (pitman) arm.
- Take the steering gear out. If you turn it 90 degrees it will slide out, even over the fog light (or horn), through the front end of the car.

Completely disassemble the gear. It's very simple and straight forward.

Thoroughly clean and check all the parts.

- Pay particular attention to the peg that follows in the cam (worm gear). Its best to replace it if it is worn (Some people have been able to rotate it 90 degrees to get a fresh side, but it is best to replace it).
- Check the cam itself for any signs of wear or chipping.
- Check the surfaces that the ball bearings run on. By all means put in new bearings and outside races.
- Inspect the case where the sector shaft goes through. If it is worn, have a machine shop rebush it. Do not ream the bushings to size - reaming is not accurate enough.

Have the machine shop put it in a mill and bore it. *While it is not necessary to replace the bushing with needle bearings, it does remove a friction point.*

- Check the sector shaft for wear. This will frequently be in the nature of grooves around the shaft. If wear is minor a new surface may be achieved by having a machine shop turn the shaft to remove the grooves then hard chrome plating the shaft back to proper size. Hard chroming may also be used to oversize the shaft to account for slight wear in the steering box. A word of caution however, oversizing a shaft will not correct for uneven or oblong wear of the box.
- Wire brush the paint off the tube where it is pressed into the casting. These were originally spot-welded but it wasn't really successful to spot-weld a tin tube to an iron casting. To be sure they do not come loose braze them. One reason they loosen or break is that the 3/8" bolt at the bottom where the housing sets in the cradle is not tightened securely. That bolt has to be kept tight. It is very important that the bolt be put in before the box is installed in the car. The bolt must be put in with the nut towards the engine. The reason for this is should the nut come off, the bolt will not be able to slip out, the fender panel will stop it.

Now reassemble the steering box.

- Put the new bearings and races in the cam.
- Install the steering shaft with cam back in the housing, and replace the end plate using the shims that came out of it (this is only a starting point - see below for final adjustment). Lightly lubricate the bearings with motor oil for now. When installing the end plate do not tighten the bolts up quickly, tighten them slowly and evenly making sure

that you can always turn the shaft. You will have to play around with the shims by adding or taking out shims of various thickness until you get the shaft tight enough that you almost lock it up, then tap the bottom plate with a hammer to set everything. Now readjust the shims until you have no pre-load whatsoever, but no play in the shaft.

- Replace the sector shaft (with the new peg installed) in the steering box.
- *Install a Tompkins steering kit. This is one of the few deviations from stock that really works. The Tompkins kit allows for much better adjustment of the sector shaft and the needle bearings in the adjuster and the column do make it a bit easier to steer. Put the needle bearing (Torrington B1416) in the top of the column, replacing the felt. It may be necessary to wrap a little tin shim around it to make it fit tight. Make sure that your column has a crimp or indentation in the column (some shafts may have a circlip) to keep the bushing from sliding down the shaft.*

The final step is to set up the engagement of the peg in the cam. it is set up either by the screw adjustment on the Tompkins kit or with shims under the stock top plate. The cam is not cut consistently. It is cut so that there is a high spot in the center where most of the wear is taking place by driving straight ahead most of the time. Set it up so that you have a definite drag on the shaft in the very center position. It's very simple with a Tompkins kit, you can just play with the screw adjustment. Adjusting shims on the stock plate is much more time consuming. It is very important that

once you have the adjustment set and the peg in the exact center (you can feel the drag) that you do not move it.

Lubrication of the steering box is with 600 weight oil. *The easiest available is Model A Ford rear end oil - available from any Ford restoration supplier. It is the heaviest gear oil that you can pour in there. **Do not use grease!*** In fact, if you use the stock top plate, *replace the grease fitting with a bolt to avoid putting grease in there by mistake.* Grease in the gear will just ball up and be useless. *Replace the old cork seal and metal retainer on the bottom of the box around the sector shaft with a National #240735 seal. This is a tiny, thin oil seal that presses neatly into the groove and will keep the oil from running out.*

Put the gear back in the car reversing the removal procedure and bolt it up securely.

- Put the steering wheel on with the center spoke down - don't forget you are still on the high spot. This is really important, do not turn the sector shaft until you put the steering wheel. (If you are doing a total dismantle, or plan on removing the front axle omit the next steps until you are ready to reassemble the front end.)
- Put the drop arm on the shaft. The original shafts (and most of the replacement shafts) have a register mark and there is a register mark on the drop arm; they should line up. When correctly fitted the drop arm should be straight with the long axis of the car. Obtaining this alignment is more important than matching registration marks.
- Visually set your front wheels so they are straight ahead. Use the same technique discussed in the alignment section (page 21). Now install the drop arm.
- If your steering wheel spoke is a little bit off, center it by twisting the track rod.

Final adjustment cannot be made until the alignment is completed and the car is road tested. On the road, leave the jamb nuts on the drop arm loose until you can get exact centering of the steering wheel spoke, then tighten them.

Track Rod and Drop Arm

The next step is to begin dismantling the front end.

- Start by removing the track rod (the rod between the front wheels – also called the tie-rod) and the drop arm (the rod between the left front wheel and the steering box – also called the drag link).
- Knock the balls out of the steering arms.
- Remove the front hubs and the backing plates complete with the brakes. Set them aside.
- Check that the track rod and the drop arm rod are not bent. Take the ends off and roll them along a flat surface. You can see if they wobble at all. If so, it means they are bent and the only thing to do is to throw them away and buy new ones. They can be straightened in a lathe but that is a last resort. Remember that the track rod, in particular, is in compression - that's all that holds the wheels running true. A tube in compression is very strong, but once it gets a slight bend it will continue to bend and you will have alignment and toe-in problems.
- Next check the track rod and drop arm balls that were taken out of the steering arms. They should be perfectly round.

On either side of the ball is a cup that has a hole through it. That hole is for the lubrication to get to the ball.

For whatever reason, probably because 99% of your driving is in a perfectly straight-ahead position, the ball wears to an oblong shape with a projection on it at the point of the hole in the cup. The problem this creates is, while driving, you start to drift, so you correct a little, subconsciously. Nothing happens, so you correct a bit more. Again, nothing happens, so you correct some more. The reason nothing is happening is the spring tension is keeping that projection on the ball in the hole in the ball cup. Finally you apply enough pressure to overcome the tension, but it releases very quickly and you oversteer. Now you correct back and it goes off the other way. The result is you end up weaving down the road instead of going straight. The ball can be turned 90 degrees to get a fresh surface, but it is best to replace them. Just changing that ball will probably solve a lot of handling problems.

The ball unit used in the drop arm is made with a tapered shaft. It has to be assembled by putting in the ball cup with the hole in it, then inserting the shaft through the side hole then putting in the ball cup, spring, and plug. That's so that if the link end does get loose from wear it can't fall off the ball. The spring location is also different to provide constant spring tension for left or right turns.

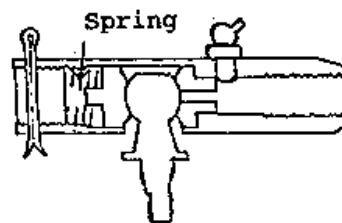

Figure 2 – Drop arm assembly

The track rod is different because, by design, both wheels are trying to turn outwards as the car moves forward. This

causes the pressure on the balls to continually push towards the springs.

The ball unit for the track rod is a straight shaft. It is assembled by first inserting the spring, then the ball cup with the hole, ball unit, solid screw-in ball cup and finally the split pin.

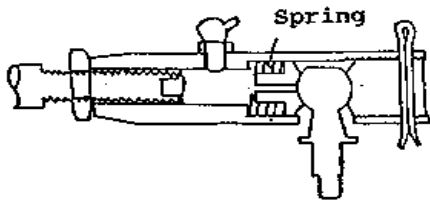

Figure 3 – Track rod assembly

It should be noted that the track rod ends and the drop arm ends are **NOT** interchangeable

The springs in the ends provide a means of applying appropriate tension for proper steering and dampen out any vibration transmitted from the road and rotating wheel along the steering arms. When steering to the right the ball in the drop arm end pushes against a solid mounted cup. The drop arm transmits the movement to the ball in the steering arm end through the spring. If standard track rod ends are used on both ends of the drop arm, movement would be transmitted either through two springs or no springs depending on the direction of the turn. This would give a different feel and different vibrations depending on the direction of the turn.

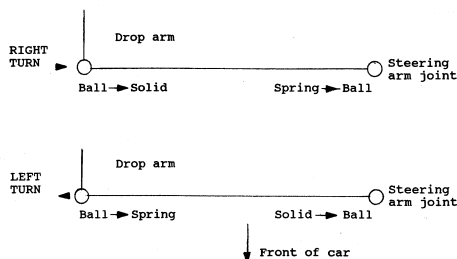

Figure 4 – Transmission of forces

Adjusting the ends:

- The best adjusting arrangement for the end plug is to tighten it up tight and then back it off about a quarter to a half a turn to the nearest split pin slot. There really isn't much adjustment there. You don't want it really loose, and you certainly don't want it tight. A slot machined at 90 degrees from the original slot in the end cap, or, drill a new set of split pin holes at 90 degrees from the original pair will give greater adjustment flexibility.

NOTE: This would be a good time to redo your brakes if necessary. Every thing you need to get to is exposed at this point.

Front springs

The front springs and their mounts are another source of concern. After all these years springs tend to sag or they may be broken.

- As a quick check, there should be approximately 2" between the conical shaped rubber buffer and the buffer pad when the car is on the ground (loaded clearance should be at least $\frac{3}{4}$ ")
- Individual spring leaves may be badly worn especially at the point where an adjacent leaf ends. As they flex, the ends dig into and wear the leaf next to it. You can replace the springs or have them rearched to factory specifications. If you replace them make sure the length, mounting centers and arch (tension) are as original. Some replacement springs are much too stiff. A considerable improvement in spring action can be obtained by grinding off all sharp edges on the ends of each spring leaf. *Some additional spring action can be achieved by the use of teflon strips between each leaf (a trick*

from the Ford Model A restorers). Grease applied between the spring leaves will soften the ride. A simple greaser can be made from a piece of 1/4" tubing about 2" long. Tap one end 1/4" nf and install a grease nipple. Flatten the opposite end and file a notch on each side about 3/4" from the flat end. Insert the tool between the spring leaves and pump grease between the leaves with a grease gun

- New rubber or urethane bushings should be installed if yours are bad.
- Also check the shackle pins. If rusted or worn, replace them.
- The front mounting bolt/pin may be badly worn also. It has a grease fitting on the head, remove it and clean the grease passage thoroughly. Replace the pin if it shows signs of wear, rust or if it is oblong.
- A special note is required about reinstalling the rear bushings for the front springs. New upper and lower bushings bought today are the same length. Originally the lower ones were shorter. You will need to trim about 1/8" off each of them, because the frame is wider than the spring and the shackle plate has a 1/8" washer brazed on the inside to accommodate the different widths.

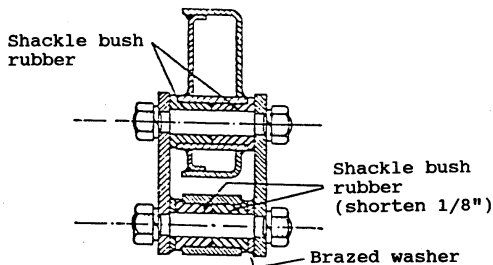

Figure 5 – Front spring, rear shackle

- If the shackle pins are rusted put in new ones.

- Check the condition of the shock link pins. Replace if necessary.
- This is a good time to check the rear springs also. The condition of these springs can have a major impact on overall handling. Everything said about front springs applies to the rear. Special attention should be given to leaf wear and sagging or broken springs. Repair or replace as necessary.

Front Axle

The next step is to check the front axle. Over the years most TC axles have become bent from hitting a lot of pot holes, an occasional curb and other assorted things. Eventually, or if you hit objects hard enough, it's going to shear or at least badly bend the buffer pad bolts. Also, when you hit something it tends to push the wheel back and the axle pivots around the buffer pad bolts and it will bend the center of the axle. You can check this visually or with a string line.

- It is easy to straighten the axle yourself either on or off the car. Use a stout chain (5/16 works well) and a 3-4 ton (minimum) bottle type hydraulic jack. You need a jack that works in a horizontal position if you are working with the axle still in the car.
- If the axle is bent in the middle between the springs, tie the chain around the outside of the springs (pads, if the axle is out of the car) make a double-wrap, bring it to the front of the car, and take a double-wrap around the other spring and then back and secure it. Leave enough space to get the jack between the chain and the axle, in a horizontal position.
- Put the jack in the center of the bow and start pumping until you go just a tiny bit past center -just a tiny bit -and release the tension and check for straight. If you haven't gone far enough,

do it again. Do not go to far. It is almost impossible to bend it back the other way if the spring is in the car.

- If the bow is, as they usually are, off to one side wrap the chain on the outside of the spring on that side and inside the spring on the other side. Now place the jack directly over the bend with an equal length chain on each side.

Straightening the axle is really quite easily done, and you don't have to take it to a frame shop to have it done. A word of caution -**NEVER use heat** on an axle and only bend on the "I" beam portion inside the spring mount pads.

If the axle is twisted it will have to be straightened by a machine shop with some heavy equipment. A minor twist, however, can be corrected by the use of shims. See page 19 for a discussion of how this is done.

One area that you want to check very closely is the buffer pad bolts. They have a hex head that is 1 ¼" tall and tapped for screws, and the reason it is there is to mount the buffer pad plate that goes on top of the axle. The plate is retained by four counter-sunk screws. You'll find a lot of TCs have those plates missing. People have just used either the tall hex bolts without anything on the top, or they used short bolts. Those tall hex bolts and that pad should be there. It not only provides a surface for the conical shaped buffer to strike, but it also helps support the entire spring assembly. Those bolts go down through the axle, past the spring, and through a square plate that has six holes in it -four holes for the buffer pad bolts and two holes for small studs that actually hold the spring together. The

small studs aren't vital to replace if they are missing. It is very important that underneath the plate there are, or should be, two stiffener plates. These go on the buffer pad bolts and then the nuts go on. They are used for extra support on the bottom plates. You'll see a lot of them missing but they are a necessary item. When you are all done, tighten up the nuts from the bottom *and then double-nut them. Remember, when double-nutting, tighten the first nut, hold it with a wrench, and tighten the second one to the first; you don't just tighten the bottom one up.*

Now that the axle is straight, remount the axle on top of the springs. You need to determine that the axle is in the right way around. This is very important. There's a front and back to the axle.

- The easiest way to check it is to set it on a flat surface, a table or the floor, and visualize putting a ¾" rod down where the kingpins go. The rod should tilt back 3 degrees. It is important to get it in the right way around; they will mount two ways and if you get it in backwards you're not going to have enough caster angle.
- If the car had caster chips, you may want to replace them. (For a complete discussion of caster chips see page 18-19.)
- Make sure the buffer pad screws are tight.

Before installing the spindles and king pins is the time to check the caster angle.

- Put a ¾" diameter rod through the king pin hole in the axle.
- Place a protractor with a bubble level against the rod.
- Level the bubble and read the angle. It should be approximately 5 ½ degrees with the chips installed, 8 degrees without the chips.

King Pins

Kingpins are retained with a tapered bolt, threaded ¼ BSF on one end and a big nut on the other end which is peened in place (some of the new ones supplied in kits today have a special headed bolt that does not require peening). The pin also has a flat spot to retain the king pin. The pin goes in from the back of the axle, registers the flat spot on the kingpin and the small nut goes on the front and is peened over. The large nut on the back acts as a steering stop.

- To pull these kingpins, remove and save the dust cap and bolt on the top and take the nut off the front of the retaining pin.
- Use a big steel hammer and hit the retaining pin as hard as you can, once or twice. If it comes out, fine. Usually, 99% of the time, it doesn't, and you are going to wreck the threads. Don't worry about it, the bolt should be replaced as part of a new king pin set anyway. Take a cold chisel and cut the pin flush with the axle and take a big tapered punch (1/4" end) and put it in the stub end and drive the pin out and throw it away.
- The kingpin should come out fairly easily. It should be a drive fit, but it should come out fairly easily using a soft drift and a hammer. Drive them either up or down. If the king pin eyes are out of round or loose there are several alternatives: heat shrink the eyes and bore, ream or hone to size; have them bored out and install a bushing; or use oversized king pins (There are pros and cons to each of these alternatives, and which one is best will surely generate much discussion and opinion).

- The spindles will now come off the axle.

Spindles

The TC is not a big, heavy car, but still the front spindles are a little bit small. Because of this (and the fact that the metallurgy of 50 years ago was not as good as today) the spindles can crack. They invariably will crack at the base where the radius is - where the spindle joins the main part of the forging.

- Since you have stripped down the front end, have the parts magnafluxed, especially the spindles. It's very cheap because you don't need a certification, which costs you a little more. The original one piece front spindles are irreplaceable So treat these spindles like gold. (See Sherrell, page 103 for a discussion on how to build a new spindle. There are also several sources for replacement spindle stubs.) While you are having the spindles magnafluxed also do the steering arms (left and right), the drop arm, the sector shaft and the cam and column (treat it as a unit). Magnaflux shows up a crack. Cracks start at rough spots, sharp edges, etc. If you have a highly polished surface or a good radius on a fillet a crack doesn't start. You can reuse a lot of parts including spindles that are rejected if you catch them in time, polish out the cracks and have it re-magnafluxed.
- New king pin bushings should be installed. This procedure is described in detail in the TC owner's manual. Note: the king pin bushes are grooved and have a slot from the groove to one end. This end should face the axle beam to allow lubrication of the thrust washer and top and bottom of the axle beam. The final fit should allow the king pins to fit rather snugly, while at the same time permitting the spindle to move freely from stop to stop.

- When refitting the spindles to the axle, be aware that front right side has a right hand thread and left front side has a left hand thread. They are mounted so that the nut tightens as the hub rotates forward in the event of a seized wheel bearing.
 - When the spindle is fitted to the axle, the weight of the car is supported on a bronze thrust washer, .125" thick. This washer should be replaced. Wear has undoubtedly worn down the washer as well as opened up the clearance well beyond the prescribed .004" vertical clearance when the car is unweighted. Install steel shims above the axle beam to achieve the 0.004" *Note: Some people have used Torrington needle bearings (part no. NTA-1220 with hardened (stainless) thrust washers (several thickness available) in place of the bronze washer. Experience has shown several problem with this modification. They are hard to lubricate (even with grooves machined in the king pin or notches in the thrust washer) because the thrust washers fit so tight to the king pin. Also if there is any other front end problem the car has a tendency to oversteer.*
- spinning fast as you blow it out. If they spin real fast unsupported they will disintegrate and they can possibly put out an eye or cause other serious injury. They are like shrapnel when they go.
 - Feel the bearings; if they are at all rough or have drag spots, replace them. Bearings are cheap.
 - Pack the bearings by hand or with a wheel bearing packer. Use the fibrous type heavy-duty wheel bearing grease. Do not use the high-temp disc brake grease. Disc brakes are designed differently, and the grease melts but they have seals to retain it. If you use the high-temp grease on a TC for wheel bearings or wipe it on the splines under the wheels it will just run out like water when it gets hot.
 - After packing, install the bearings back in the hub **with the spacer** between them. The spacer is bad if it has cracks or get grooves around it and should be replaced. *See Appendix A for a brief discussion of the use of tapered roller bearings.*
 - Put in a new seal. Smear some grease around the seal and around that little cup-shaped spacer that goes on the spindle. This spacer fits over the radius on the spindle and the seal sets on it.
 - For reassembly, set the hub on the spindle and be sure you get them on the proper side. They also have right and left hand threads. Temporarily put the knock-offs on to be sure the hubs will be mounted correctly (the knock-offs are marked for right and left sides). If you reverse them you can lose a wheel. Setting the knock-off on a little extra tight thinking it won't come off won't work. They will come off if you've got them on backwards. They're self-tightening, but they're also self-loosening.

Hubs

Dismantle the hub.

- When removing (or assembling) the bearings use a press if you can. If not use a drift pin or punch. Use the drift against the outer edge of the bearing. You should never knock the center of a bearing.
- Once disassembled clean the bearings with solvent and blow them out with compressed air. **WARNING!!** - Don't get the bearing

Now one of the most important parts of this area of the car is the next item to go on. It's a rather funny shaped washer with some holes in it. The holes, surprisingly enough, are there to pack the bearing (if you can imagine sitting down and thinking you could pack wheel bearings through those little holes).

This washer is cupped with a slight dish shape so that when you tighten the nut it tightens against the inner part of the bearing, which tightens against the spacer tube, which tightens against the inner part of the inner bearing, which tightens against the spindle. It is made this way so the wheel will revolve freely when you tighten the nut. Tighten the castellated nut down snug enough to ensure that the bearings are seated all the way home (about 10 ft-lbs. of torque). Back off the nut at least one full flat of rotation, then loosen a bit more until the next gap lines up in the nut and insert the split pin. (This should give about 0.005" clearance) This is a very different from American cars that are designed to have a slight amount of play.

If you put the washer on the wrong way around so that it bows out, it's going to tighten on the outer part of the bearing. If you do this the wheel will not turn. If you back the nut off to where the wheel turns and put the cotter pin in, the nut will now be just finger-tight. The first time you go around a turn, the hub bearing assembly will try to move out contacting the outer part of the washer. Eventually it flattens the washer out and turns it blue because of all the friction. You've now got probably a sixteenth of an inch of play and the bearings can moving back and

forth. The constant pounding this sets up is a major contributor to spindles cracking.

Lubrication

- The front end should be lubricated frequently. Every 500 miles for the king pin thrust washers is not too often.
- When doing this lubrication make sure the front end is jacked up to take the pressure off the spindles and king pin thrust washer. This will allow the grease to get all the way into the thrust washer.

ALIGNMENT - some basic theory

Alignment has to do with the geometry of the entire front end. It is not the purpose of this discussion to delve deeply into the theory, but rather to briefly talk about the basics. There are three primary angles that set up the geometry of the front end. They are: camber, caster and toe-in. That's more or less their order of importance, also.

Camber

The camber is the outward tilt of the wheels. If they're tilted out at the top like we're used to seeing on the TC, that's known as positive camber; if they're in at the top that's known as negative camber. If they're absolutely perpendicular to the ground, vertical, it would be zero camber. Camber is built into the axle when they are made and short of bending the axle cannot be changed.

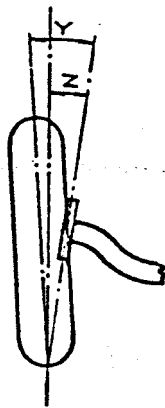

Figure 6 – Camber angle

- The steering knuckle angle (y) and the king pin angle (z) determine camber. Camber angle on the TCs should be 3 degrees on the curb side, plus or minus half a degree. It can vary slightly

from side to side without hurting anything.

Caster

The second important front wheel angle is caster. Caster is the backward tilt of the kingpin towards the rear of the car. If tilt is to rear, caster is positive

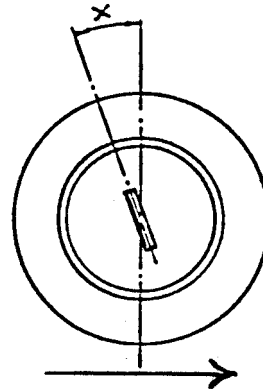

Figure 7 – Caster angle

The stronger the caster angle (the higher the caster angle) the straighter and truer the car will track, and the harder it is to steer. Conversely, the less the caster angle, the easier it's going to steer but the more it's going to wander at higher speeds.

- The TC's original specifications call for 8 degrees total caster angle. If you recall the discussion of the front axle you'll remember that there is 3 degrees of caster built into it. So to achieve the total specified caster angle the spring angle on the frame must provide the additional 5 degrees. The the springs will settle as they get older, therefore the caster angle will decrease. That is why having correct spring arch is so important.

Commencing at TC 4251, tapered packing was inserted between the axle and the spring to reduce caster, installed with the heavy part back, which tilted the axle forward, which gave it a lesser caster

degree (5 ½) and, therefore, easier steering.

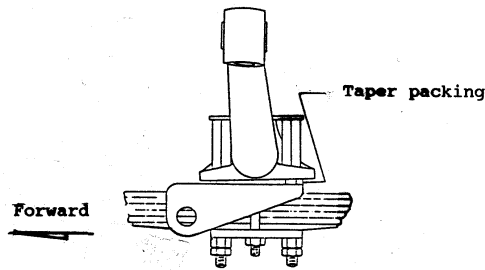

Figure 8 – Taper packing to change caster angle

If you put them in the other way around you would have almost 11 degrees caster. Steering will be very hard but the car will track very well on the freeway. Conversely, too little caster and the car will wander.

Even before the days of caster chips you could buy a universal caster shim or you could make them out of tin. You simply start folding pieces of tin progressively over each other until you've got enough of a wedge.

- By varying the angle created by the shims - precast or your own - you can compensate for a twisted axle and actually straighten it out.

The use of varying numbers and thicknesses of shims can produce lots of combinations that can solve almost any problem. The TC front end isn't sensitive to a little alignment deviation, certainly not like the independent suspension cars.

Everything else being equal, and if roads were perfectly flat, you would want the caster angle the same on both sides because a car will pull to the side with the least caster.

- To make the TC handle a bit better on the crown of our American roads give the right hand side half a degree more caster than the left

and this will help keep the car going straight.

Toe-in

The last wheel alignment angle is toe-in. Toe-in means the wheels are closer together in the front than in the back. In theory when you're going straight ahead down the road, your wheels should be perfectly parallel. When you do the alignment you will be doing it in static conditions, and therefore, all cars need a slight amount of toe-in. There are lots of reasons for that. A rolling wheel in a perfectly vertical position is going to roll straight to infinity. If it tilts a bit, it's going to roll off in that direction. So the more camber you have in a car, the more it's going to tend to make the wheel roll off. On the TC, the right one's going to want to go to the right, the left one's going to go left.

- Since the TC's are running a stronger camber angle than average - average being 0 to ½ degree - you want a slightly stronger toe-in than on most cars. It should be between 1/8 and ¼ inch. A good compromise is 3/16 inch.

Also, as you drive the track rod actually does flex, it tends to compress (bow) slightly. As mentioned earlier, there are springs in the tie-rod ends, so as you're driving down the road this 3/16 inch of toe-in is going to be compensated for and the wheels are going to go straight ahead.

Steering arms

One other important item that is a little hard to check, but one that is very critical, is the angle of the steering arms. The TC's use a steering system known as the Ackerman type.

To describe it briefly, think back to the horse and buggy days when a four

wheeled cart was used. The front axle would pivot around a center point. Going through a turn, a line drawn through the front axle and a line drawn through the rear axle would meet at a point. This would be the center of the turn. In a turn like this all the wheels are just revolving, but the outside wheel is going faster because it is on a longer radius than the inside one.

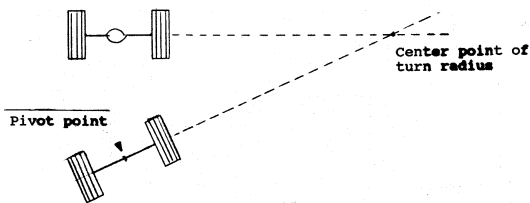

Figure 9 – Single pivot turning radius

The Ackerman steering has a totally different geometry. The combination of axle, steering arms and tie-rod forms a rectangle.

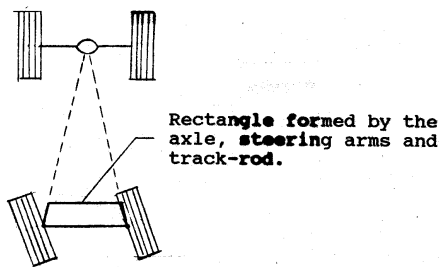

Figure 10 – Ackerman steering principle

To illustrate what happens with this type of geometry imagine taking two cupboard doors and opening them up so the doors are 90 degrees to the shelves. Tie a piece of string between them to keep them parallel. No matter how you move the doors they stay parallel to each other. The doors pivot on their hinges just as the steering moves around the king pin. In a car turning with wheels parallel the outer wheel will drag through the turn. Now back the cupboard doors. Take the doors and bring them in at a slight

angle and retie the string. Now move one of the doors and you will see that the other door comes in very fast. That is the principle of Ackerman steering. The different angle of the wheels allow them to track together through a turn without one dragging. On a car such as the TC with a steering arm in back of the axle, the arms will always incline inward. On a TD or a car where the steering arms are in front, they will incline outward. In theory, lines extended through the steering arms will intersect in the center of the rear axle. If the steering arms are bent, the entire front end geometry changes. It will not affect the straight ahead driving but in a turn it's going to give excessive tire wear.

- To check the angle of the steering arms measure the distance between the arm and the backing plate. It should be the same on both sides.

ALIGNMENT - how to

The next part of the process is doing the actual alignment of the front end. We've discussed all the different angles - camber, caster and toe-in - now how are you going to check it?

The equipment

You can very easily build your own measuring equipment and use it to check all the necessary angles. Use a straight, true piece of 2" x 2" hardwood long enough to reach from rim edge to the opposite rim edge. Each end has a 2" block added to bridge over the knock-off. A machinist protractor-square with leveling bubble is wired to the hardwood bridge. The whole thing is held to the wheel with elastic cords.

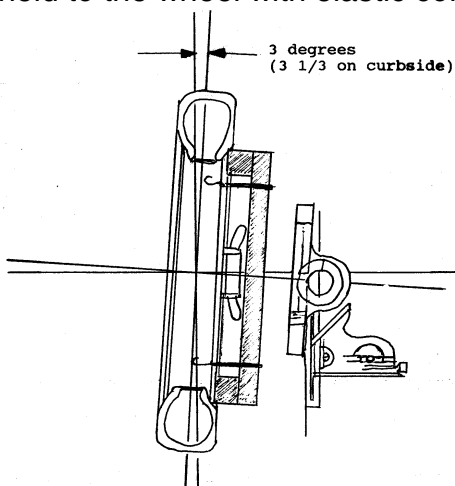

Figure 11 – Simple measuring device

When mounting make sure the wheels are true and the block is not on the high spot created by the weld. It may be necessary to notch the hardwood bridge to clear the knock-off if the ears are in the way.

Preparation

Taking these set up steps will make your job easier and much more accurate.

- Jack up the front end, take about a tablespoon of clean motor oil and put it on the cement floor. Make sure that you've got a pretty level floor.
- Let the car down so that the entire footprint of the tire is sitting in oil and kind of roll the car back and forth a little bit, turn the wheels by hand so that it is really oozy; the oil won't hurt the rubber. The reason for this is because the suspension has to be loaded to accurately check the alignment. When dealing with a solid-axle car there isn't a tremendous amount of play in the front end like there is with independent suspension cars. If you visualize a car with independent front suspension and jack the front-end up the wheels fall way in. When you let it down they will stay in that position until you start driving and then they assume their correct position. By putting the car in oil and moving the car around a little bit, maybe bouncing it a bit, the wheels will assume the same position they are going to be in out on the road. This is very important for correct alignment.
- Next, sight, like a gun sight, along the lower inner edge of the front tire to the back one on the same side. Just look along it and you should see a point on the rear tire, probably the inside of the tread on the tire. The idea here is to get your front wheels so you see the same point at each rear tire so you will know that the front tire are set straight ahead.

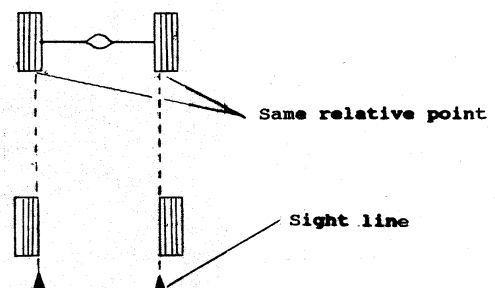

Figure 12 – Sighting front wheels

- The next step is to make sure that the wheels are the same height. Measure from the underneath part of the chrome knock-off down to the ground. Vary the tire air pressure to make them equal height. Obviously, if you have ten pounds more pressure in one tire or a larger tire it's going to tilt the front-end and give you a stronger camber reading on one side than on the other.

Camber

With the front-end level, and the wheels straight ahead. put the hardwood bridge with the protractor on the left wheel, mounted vertically. Set the bubble level in the protractor. Now read the degree setting. It should be 3 degrees. Do the same on the other side. Assuming that the camber is off, let's say that you find the situation where the camber angle has dropped to 1 or 2 degrees and you want to bring it back to its standard setting of 3 degrees, you must bend the axle. (See discussion on page 13-14.)

Caster

Because the caster is determined by the combination of the rear tilt of the king-pin (cast into the axle) and the front spring mounting you cannot assume that the correct angle has been achieved. It must be measured.

- With the wheels straight ahead and the protractor mounted vertically (to either wheel) turn the wheels to the right and sight along the bottom inside edge of the tire to a point or spot on the opposite rear tire. This will approximate a 30 degree turn. Be sure to identify the spot on the rear tire and be able to find that same relative spot on the other rear

tire later - the edge of the tread is a good thing to use.

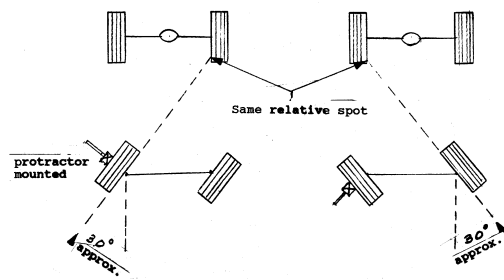

Figure 13 – Sight lines for measurement

- Set the bubble level and read the degree indicated. Write it down.
- With the protractor still mounted, turn the front wheels in the other direction the same amount. Sight along the tire adjusting the amount of turn until you can find the spot similar to your first one.
- Set the protractor bubble level and read the angle and write it down.
- Now subtract the lowest number from the highest number and that is your caster angle for that wheel.
- Repeat the process for the other wheel.

To make any corrections use shims as described earlier (see page 18-19).

Toe-in

The next thing to set is toe-in.

- Jack up one wheel at a time and scribe a line all the way around the tire between two of the tread groups. The easiest way to do this is to use a milk crate or similar size box to rest a scribe on. The scribe can be made from a file point, ice pick or similarly sharp pointed object. This operation is most easily done with two people -one to hold the scribe and the other to spin the wheel. As you are doing this you can see very quickly if your tire is out of round or if your wheel is not running true.

- Now let the car down, jack up the other side and repeat the process. Put the scribe line in the same place on both tires.
- Using some wood long enough to span the distance between both tires and some angle brackets make a tram that will go across the ground and come up with two adjustable pointers on it (Several years ago Moss illustrated a neat device consisting of 2 carpenters framing squares that works great)

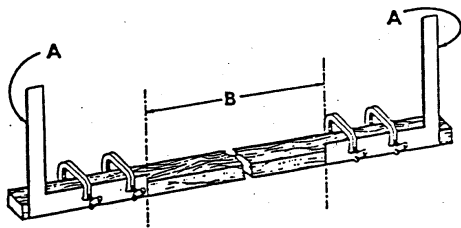

Figure 14 – Toe-in measuring device

- You can't use a tape measure because you can't get in back to measure accurately.
- Set it up so that the pointers contact the lines at the front and mark or measure the distance, and then move it around to the back. Set it so that one of the pointers contacts one of the lines.
- Measure the distance between the edge of the other upright and the other line, or reset the uprights and measure the new distance (B in the illustration) and subtract the original measurement. It should be about 3/16" wider in the back. If not adjust the tie-rod accordingly, and repeat the entire measuring process until that dimension is achieved.

When you adjust toe-in it is important that you have the car tires sitting in the oil and move it back and forth to achieve proper loading and to allow the tires to move as you adjust them.

Well, now you have done it!! One final check of the data and a good lube job is all you need. The whole system has been checked and you are ready to be on your way for many enjoyable hours of smooth motoring.

APPENDIX A

Tapered Roller Bearings*

The idea of using tapered roller bearings for the front end of the TC first appeared in an article by Doug McGowan in the April 1978 TSO (page 33). Few modifications to the TC have generated so much heated debate.

Drawing on the experience of American cars with roller bearings being set up with some play, it was suggested that the spacer between the two bearings be eliminated. It is the elimination of the spacer that seems to have created so many problems. It should be remembered that the stub axle of the TC is somewhat delicate and fragile. By design, much of the front end load was carried by the whole assembly of bearings, spacer, washer and nut creating a much larger effective diameter and therefore stronger unit. Years of experience has shown that allowing the spindle alone to carry the load lead to the spindles failing.

When (if) converting to tapered roller bearings in the front hub is important to realize that you can not assemble the bearings with the old spacers. The tapered rollers have an offset between the inner and outer races which results in a longer space between the races of the two bearings than the length of the original spacer. This offset needs to be compensated for by making up an additional short spacer or use shims to achieve the end float or bearing clearance (measured with a dial indicator) of about 0.002" – 0.005". It will take some "fiddling around" to get it right. (There are several sources for new spacers of the proper length or short spacers to use with your original

one; shims from an MGB could also be used.) They all, however, still require some test fitting and additional shimming. You must torque up the stub axle nut tight and insert the split pin after the shimming is completed.

A complete set of tapered roller bearings consists of bearing part numbers:

- *Timken – (4) 07204 cups, (2) 07079 cones and (2) 07097 cones*
- *SKF – (2) SKF-30205 inner bearings (cup and cone) and (2) SKF-30304 outer bearing (cup and cone).*

Properly set up, roller bearings have proven to be very successful.

*A special thanks to Bob Grunau for the information used here